

Issued by: Mitsubishi Electric Europe B.V. - UK Branch
 Document issue: V1.00
 Produced by: - CTC
 Travellers Lane, Hatfield, Herts, AL10 8XB, UK
 Author: Matt Wills

Databank - Technical Bulletin

This Data Sheet covers the connection of the QD75M1-H, QD75M2-H and QD75M4-H modules to the MR-J3 Servo Amplifier along with Control I/O.

Amplifier Power Circuit:

(Single Phase 200-230VAC)

Wiring requirements for MR-J3-B type servo amplifiers (d01 and d02)

- 200 - 230VAC to L1 and L2 on both servo amplifiers (d01 and d02)
- Fibre optic cabling CN1A (d01) ↔ 20SSC-H; CN1B (d01) ↔ CN1A (d02)
- U, V, W (d01) → motor 1; U, V, W (d02) → motor 2
- CN2 (d01) → motor 1; CN2(d02) → motor 2

Optional:

- 24VDC ±10% to CN3 on both servo amplifiers (d01 and d02)

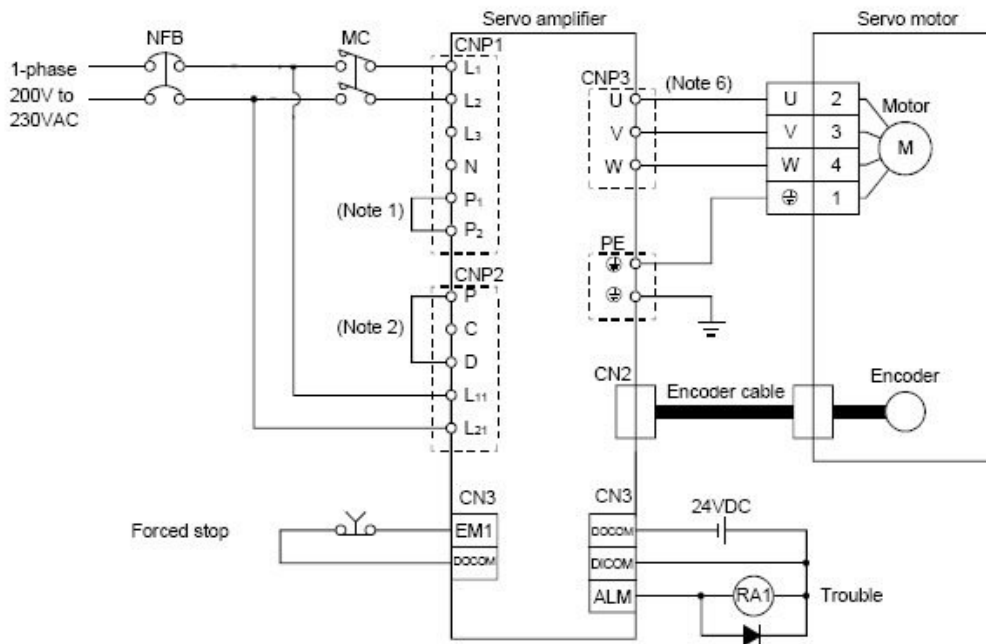

Note 1: Always connect P1 – P2 (Factory Wired)

Note 2: Always connect P – D (Factory Wired)

Issued by: Mitsubishi Electric Europe B.V. - UK Branch
 Document issue: V1.00
 Produced by: - CTC
 Travellers Lane, Hatfield, Herts, AL10 8XB, UK
 Author: Matt Wills

Databank - Technical Bulletin

Grounding:

Ground the cables as follows:

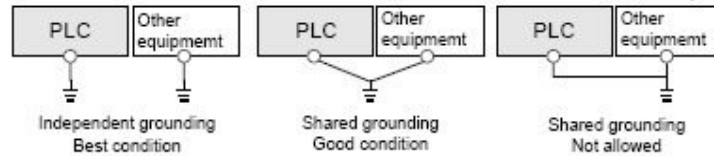

Electrical specifications of external input signals

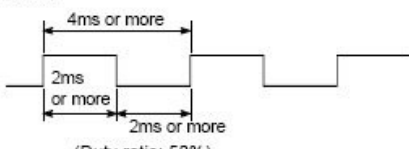
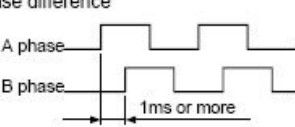
Signal name	Rated input voltage/current	Working voltage range	ON voltage/current	OFF voltage/current	Input resistance	Response time
Forced stop input signal (EMI) Upper limit signal (FLS) Lower limit signal (RLS) Stop signal (STOP)	24VDC/5mA	19.2 to 26.4VDC	17.5VDC or more/ 3.5mA or more	7VDC or less/ 1.0mA or less	Approx. 6.8kΩ	4ms or less
Manual pulse generator A phase (PULSE GENERATOR A) Manual pulse generator B phase (PULSE GENERATOR B)	5VDC/5mA	4.5 to 6.1VDC	2.5VDC or more/ 1mA or more	1VDC or less/ 0.1mA or less	Approx. 1.2kΩ	1ms or less
	① Pulse width  ② Phase difference  When the A phase leads the B phase, the positioning address (current value) increases.					
Near-point dog signal (DOG) External command signal (CHG)	24VDC/5mA	19.2 to 26.4VDC	17.5VDC or more/ 3.5mA or more	7VDC or less/ 1.0mA or less	Approx. 6.8kΩ	1ms or less

Issued by: Mitsubishi Electric Europe B.V. - UK Branch
 Document issue:V1.00
 Produced by : - CTC
 Travellers Lane, Hatfield, Herts, AL10 8XB, UK
 Author: Matt Wills

Databank - Technical Bulletin

External Device connector signal layout

The QD75Mx-H module uses an A6CON1 40 pin connector. For the 1 and 2 axis units a single A6CON1 is used, for the 4 axis module 2 A6CON1 connectors are used.

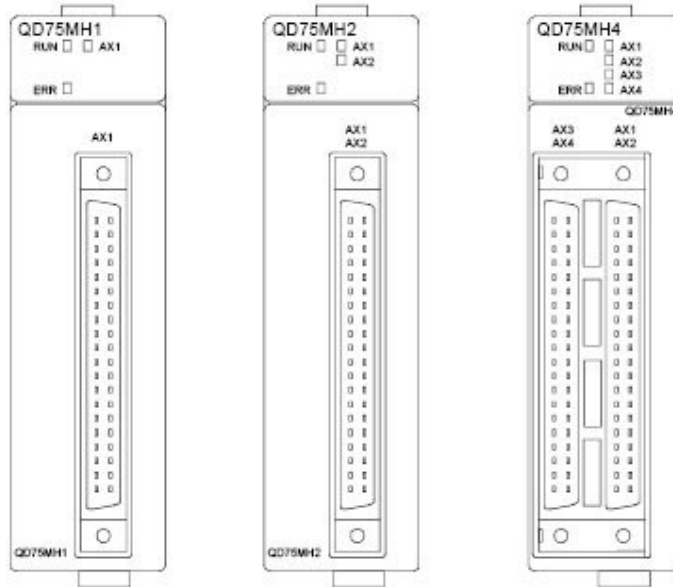

The Pin-outs are as detailed below:

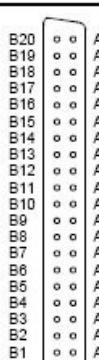
Pin layout	Axis 4(Ax4)		Axis 3(Ax3)		Axis 2(Ax2)		Axis 1(Ax1)	
	Pin No.	Signal name	Pin No.	Signal name	Pin No.	Signal name	Pin No.	Signal name
 <p>Front view of the module</p>	2B20	No connect	2A20	No connect	1B20	PULSER B-	1A20	PULSER B+
	2B19	No connect	2A19	No connect	1B19	PULSER A-	1A19	PULSER A+
	2B18	No connect	2A18	No connect	1B18	No connect	1A18	No connect
	2B17	No connect	2A17	No connect	1B17	No connect	1A17	No connect
	2B16	No connect	2A16	No connect	1B16	No connect	1A16	No connect
	2B15	No connect	2A15	No connect	1B15	P5	1A15	P5
	2B14	No connect	2A14	No connect	1B14	SG	1A14	SG
	2B13	No connect	2A13	No connect	1B13	No connect	1A13	No connect
	2B12	No connect	2A12	No connect	1B12	No connect	1A12	No connect
	2B11	No connect	2A11	No connect	1B11	No connect	1A11	No connect
	2B10	No connect	2A10	No connect	1B10	No connect	1A10	No connect
	2B9	No connect	2A9	No connect	1B9	No connect	1A9	No connect
	2B8	No connect	2A8	No connect	1B8	EMI.COM	1A8	EMI
	2B7	COM	2A7	COM	1B7	COM	1A7	COM
	2B6	COM	2A6	COM	1B6	COM	1A6	COM
	2B5	CHG	2A5	CHG	1B5	CHG	1A5	CHG
	2B4	STOP	2A4	STOP	1B4	STOP	1A4	STOP
	2B3	DOG	2A3	DOG	1B3	DOG	1A3	DOG
	2B2	RLS	2A2	RLS	1B2	RLS	1A2	RLS
	2B1	FLS	2A1	FLS	1B1	FLS	1A1	FLS

* 1: Pin No. "1□□□" indicates the pin No. for the right connector. Pin No. "2□□□" indicates the pin No. for the left connector.
 * 2: When a 1-axis module is used, pin Nos. 1B1 to 1B7 are "No connect".
 * 3: For 1-axis module and 2-axis module do not have AX3 and AX4 connector of the left side.

Issued by: Mitsubishi Electric Europe B.V. - UK Branch
 Document issue:V1.00
 Produced by : - CTC
 Travellers Lane, Hatfield, Herts, AL10 8XB, UK
 Author: Matt Wills

Databank - Technical Bulletin

Detail description of External inputs:

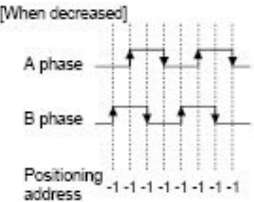
Signal name	Pin No.				Signal details (Negative logic is selected by external input signal logic selection)
	AX1	AX2	AX3	AX4	
Manual pulse generator A phase Manual pulse generator B phase	1A19 1A20	—			<ul style="list-style-type: none"> Input the pulse signal from the manual pulse generator A phase and B phase. If the A phase leads the B phase, the positioning address will increase at the rising and falling edges of each phase. If the B phase leads the A phase, the positioning address will decrease at the rising and falling edges of each phase.
Manual pulse generator A common Manual pulse generator B common	1B19 1B20	—			<p>[When increased]</p>  <p>[When decreased]</p> 
Upper limit signal	1A1	1B1	2A1	2B1	<ul style="list-style-type: none"> This signal is input from the limit switch installed at the upper limit position of the stroke. Positioning will stop when this signal turns OFF. When OPR retry function is valid, this will be the upper limit for finding the near-point dog signal.
Lower limit signal	1A2	1B2	2A2	2B2	<ul style="list-style-type: none"> This signal is input from the limit switch installed at the lower limit position of the stroke. Positioning will stop when this signal turns OFF. When OPR retry function is valid, this will be the lower limit for finding the near-point dog signal.
Near-point dog signal	1A3	1B3	2A3	2B3	<ul style="list-style-type: none"> This signal is used for detecting the near-point dog during OPR. The near-point dog OFF → ON is detected at the rising edge. The near-point dog ON → OFF is detected at the falling edge.
Stop signal	1A4	1B4	2A4	2B4	<ul style="list-style-type: none"> Input this signal to stop positioning. When this signal turns ON, the QD75MH will stop the positioning being executed. After that, even if this signal is turned from ON to OFF, the system will not start.
External command signal/ switching signal	1A5	1B5	2A5	2B5	<ul style="list-style-type: none"> Input a control switching signal during speed-position or position-speed switching control. Use this signal as the input signal of positioning start, speed change request, and skip request from an external device. Set the function to use this signal in " P7.42 External command function selection".
Common	1A6 1A7	1B6 1B7	2A6 2A7	2B6 2B7	<ul style="list-style-type: none"> Common for upper/lower limit, near-point dog, stop, and external command signal/switching signals.
Forced stop input signal	1A8	—			<ul style="list-style-type: none"> This signal is input when batch forced stop is available for all axes of servo amplifier.
Forced stop input signal common	1B8	—			<ul style="list-style-type: none"> When this signal turns OFF, the QD75MH will be the forced stop.
Manual pulse generator power supply (+ 5VDC)	1A15 1B15	—			<ul style="list-style-type: none"> Power supply for manual pulse generator. (+ 5VDC)
Manual pulse generator power supply (GND)	1A14 1B14	—			<ul style="list-style-type: none"> Power supply for manual pulse generator. (GND)

Note:

The **External Forced Stop Input Signal** is not available for negation in the QD75MxH Parameters. Therefore, even if no other external signals are to be used an A6CON1 connector must still be employed and a link made for this input. Failure to make this connection will result in the Error E7 Will be displayed on the MR-J3 Amplifier.

Issued by: Mitsubishi Electric Europe B.V. - UK Branch
 Document issue:V1.00
 Produced by : - CTC
 Travellers Lane, Hatfield, Herts, AL10 8XB, UK
 Author: Matt Wills

Databank - Technical Bulletin

SSCNET III Wiring

SSCNET III cable is made from optical fiber. If optical fiber is added a power such as a major shock, lateral pressure, haul, sudden bending or twist, its inside distorts or breaks, and optical transmission will not be available.

Minimum Bend Radius

Make sure to lay SSCNET III cable with greater radius than the minimum bend radius. If the SSCNET III cable is less than the minimum bend radius, optical transmission is interrupted and it may cause malfunctions.

SSCNET III cable	Minimum bend radius [mm] ([inch])
MR-J3BUS □ M	25
MR-J3BUS □ M-A	Reinforcement film cable : 50 (1.97) Code part : 25 (0.98)
MR-J3BUS □ M-B	Reinforcement film cable : 50 (1.97) Code part : 30 (1.18)

Connection

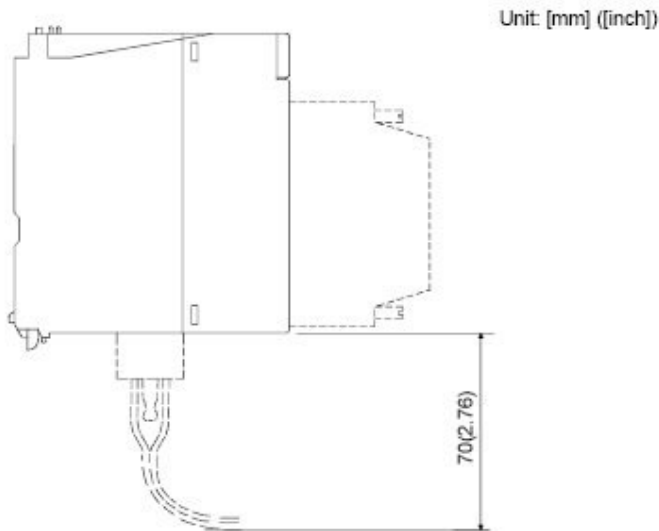

Issued by: Mitsubishi Electric Europe B.V. - UK Branch
 Document issue:V1.00
 Produced by : - CTC
 Travellers Lane, Hatfield, Herts, AL10 8XB, UK
 Author: Matt Wills

Databank - Technical Bulletin

Connection of SSCNET III to Amplifiers

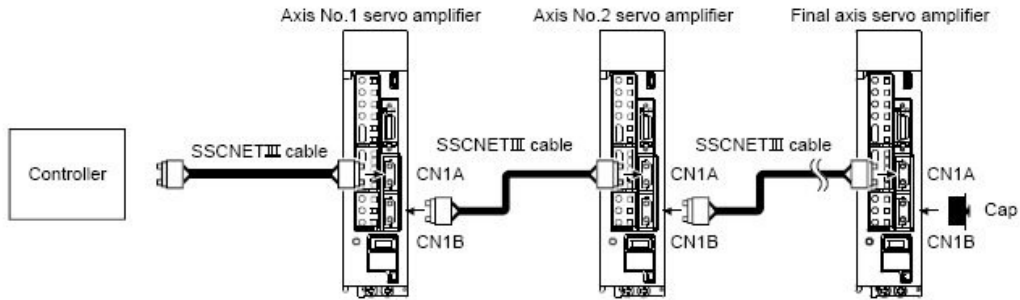

For CN1A connector of the first Axis, connect to the controller SSCNET III output.
 For CN1B connector, connect the SSCNET III Cable to the next Axis CN1A.
 For CN1A connector of subsequent Axis, connect to the CN1B connector of previous axis.
 For CN1B connector of the final Axis, fit the Cap which was supplied with the amp.

Note:

The Cap is not a terminating device, but is to protect the light device from dust. For this reason do not remove the Cap until just before mounting the SSCNET III Cable.

SSCNET III BUS Cables:

Part name	Type	Remarks
SSCNET III cable	MR-J3BUS□M *	<ul style="list-style-type: none"> • Connection between QD75MH and MR-J3-□B. • Connection between MR-J3-□B and MR-J3-□B. • Standard code for inside panel. • 0.15m(0.49ft.), 0.3m(0.98ft.), 0.5m(1.64ft.), 1m(3.28ft.), 3m(9.84ft.)
	MR-J3BUS□M-A *	<ul style="list-style-type: none"> • Connection between QD75MH and MR-J3-□B. • Connection between MR-J3-□B and MR-J3-□B. • Standard code for outside panel. • 5m(16.40ft.), 10m(32.81ft.), 20m(65.62ft.)
	MR-J3BUS□M-B *	<ul style="list-style-type: none"> • Connection between QD75MH and MR-J3-□B. • Connection between MR-J3-□B and MR-J3-□B. • Long distance cable. • 30m(98.43ft.), 40m(131.23ft.), 50m(164.04ft.)
Applicable connector	A6CON1, A6CON2, A6CON3, A6CON4 (sold separately)	
Applicable wire size	0.3 mm ² (when A6CON1 and A6CON4 are used), AWG#24 to 28 (when A6CON2 is used), AWG#28 (twisted)/AWG#30 (single wire) (when A6CON3 is used)	

*: □ = Cable length
 (015: 0.15m (0.49ft.), 03: 0.3m (0.98ft.), 05: 0.5m (1.64ft.), 1: 1m (3.28ft.), 3: 3m (9.84ft.), 5: 5m (16.40ft.), 10: 10m (32.80ft.), 20: 20m (65.62ft.), 30: 30m (98.43ft.), 40: 40m (131.23ft.), 50: 50m (164.04ft.))

(Note): The cable length of the SSCNET III cable depends on the cable type.
 MR-J3BUS□M: The cable length is 3m(0.98ft.) max. / MR-J3BUS□M-A: The cable length is 20m(65.62ft.) max. / MR-J3BUS□M-B: The cable length is 50m(164.04ft.) max.